

User manual for M4 sampling valve



Contents:

Contents:	1
Introduction.....	2
Presentation:	2
Restrictions:	3
Valve function	3
Valve bodies M4	4
Main aspects of the valve body.....	4
Main aspects of the valve body.....	5
Mounting instructions.....	6
Welding instructions:.....	6
The welding result will be best if the following method is used:	7
Block diagram for welding to pipe and tank.....	8
Keofitt valve type P (pipe):.....	8
Keofitt valve type T (tank):	8
Keofitt valve type P (pipe connection vertical):	8
Block diagram for installation with Clamp, Varivent® and Thread.....	9
Keofitt valve Clamp connection:	9
Keofitt valve Varivent®:	9
Keofitt valve Thread:.....	9
Everyday use of the valve	10
Sterilisation:.....	10
Sampling:.....	11
Maintenance:.....	11
Disassembly and assembly of valve body and head:.....	11
Instructions on replacing PTFE membrane.....	12
Spare parts list:.....	13
Valve Heads for M4:.....	14
Silicone Membranes for M4 – item no. 400051:.....	16
EPDM Membranes for M4 – item no. 400051:.....	17
PTFE membrane for M4 valves:.....	18
Upgrade from silicone to PTFE membrane:	19
For manually operated valve heads type H, K and Q:.....	19
For Pneumatically activated valve heads type N:.....	19
Update:.....	19

Introduction

Manufacturer: Keofitt a/s,
Hans Egedes Vej 19
5210 Odense NV
Denmark

Sampling valve, Type: M4
Year of production: 1998
Year of new construction: 2003

Presentation:

The Keofitt sampling valve is a valve which can be readily sterilised and which meets both hygienic and production requirements. This means that an effective cleaning and sterilisation of the sampling valve can be carried out between random samples independently of the course of the production process.

The M4 valve is 3-A and EHEDG Type E1 authorised. 3-A Sanitary Standard is an American standard which is normative for a component's ease of cleaning and sterilisation. The standard ensures optimum conditions for food products which may come into contact with the component in question. The EHEDG Type E1 certification is an European standard and it includes additional tests of bacterial increase on components that are in direct contact with the sample after the CiP process.

The valve is used in a wide range of business areas, such as breweries, dairies, and the pharmaceutical and biotechnological industries.

Warning!: During sterilisation with steam the valve will become hot, and care should thus be taken when handling the valve.



Warning!: The valve is designed for use in working conditions of up to 6 bar and temperatures of up to 121°C. It is therefore important to be aware that the rubber plug (designed for max. 3 bar) or the steel plug (designed for max. 10 bar) can be forced out at high speed if not seated correctly.

Therefore always remember to use safety goggles when taking samples because of the risk to the eyes.

Restrictions:



- The valve cannot be used for vacuum since the membrane will be sucked hard into the seat.
- The membranes are available in three different qualities: silicone, EPDM and PTFE. (the W15 and W25 valves are only available in PTFE)
- The silicone membrane has the advantage that it can in general stand higher temperatures, but it cannot tolerate moisture condensation resulting from steam sterilisation.
- The EPDM membrane is better able to cope with condensation in the steam, and at the same time can be used with the majority of CIP fluids.
- The PTFE membrane resists most CIP fluids and very high steam temperatures.

Valve function

The valve is designed to regularly take representative random samples in the production process. The valve is therefore designed such that effective cleaning, sterilisation and sampling can be carried out regularly without interrupting the production process.

Sterilisation is carried out by supplying steam through the upper of the valve's two hose pieces. It is the perfect, hygienic design in the inner part of the valve which enables absolute sterilisation in a closed state. According to an EHEDG-based test carried out by the Biotechnological Institute in Denmark, the valve is sterilised after just 1 minute's supply of steam at a pressure of 2 bar (121°C).

Following sterilisation, but prior to sampling, a sterile plug of rubber or stainless steel is fitted to the top hose piece. When the valve is opened the liquid will run out of the hose piece.

Note ! The membrane functions both as a dynamic packing in the valve seat and as a hygienic, static packing against the valve body.

Valve bodies M4

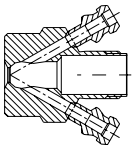

Type t
tank weld-
ing diam Ø28)

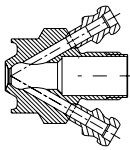

Type p
(pipe Ø1")

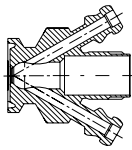

Type c
(mini clamp
25mm)

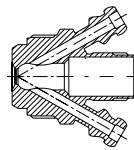

Type s
(M28 x 1,5)

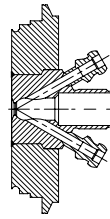

Type Varivent®
(Ø68 / Ø50 mm)

Patent: É.P.0468957 and U.S.Pat.5,246,204

Designation	Material	Certificate	Pressure, max. [bar]	Temperature max. [°C]	Surface finish Ra
Valve body	AISI 316L	* 3.1b			
Valve head	AISI 304				
Membrane (grey)	Silicone	acc. to FDA & BGA			
(black)	EPDM	acc. to FDA & BGA	6	** 121	
(white)	PTFE	acc. to FDA & BGA			
Working pressure			3		
Max. sterilisation temp.			10		
Rubber plug					
Steel plug					
Surface Int.					0.5 µm
Ext					0.8 µm

The valve heads are supplied as standard with silicone membranes.

*) A 6-digit code is marked on the valve body. This code refers to a 3.1b certificate which accompanies every consignment of valve bodies.

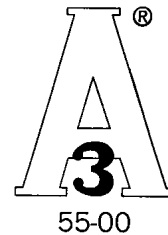

***) It is important that the steam is saturated, but dry, as condensation can damage the membrane. (dry steam at max. 2 bar)

NB! The valve is designed for use with media of low viscosity. e.g., water, finished beer, wine

Flow, cleaning (from union to union)

Flow, sampling (from valve seat to hose piece):

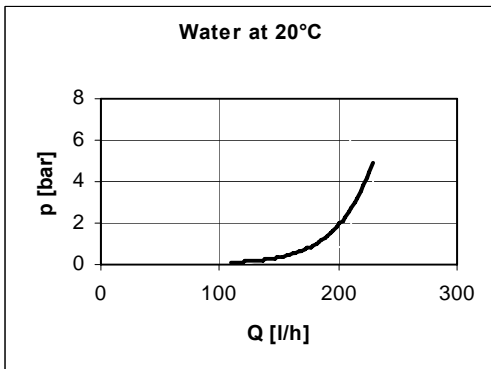

$$K_v = Q \sqrt{\frac{P}{1000 * \Delta p}}$$

$$C_v = 1.17 * K_v$$

K_v [m³/h]
 C_v [USgal/min]
 Q [m³/h]
 p [kg/m³]
 Δp [bar]

Valve capacity
 Valve capacity
 Flow through valve seat
 Viscosity of fluid
 Pressure fall across valve

Main aspects of the valve body

Dimension "A" varies according to the type of valve head mounted on the valve body. "A" is the same dimension for all valves except type N.

Dimension "B" is the same on all M4 valves 4mm.

Dimension "C" is the same on all M4 valves 5mm.

Dimension "D" varies according to the type of valve body.

Dimension "E" is variable according to type of inlet outlet

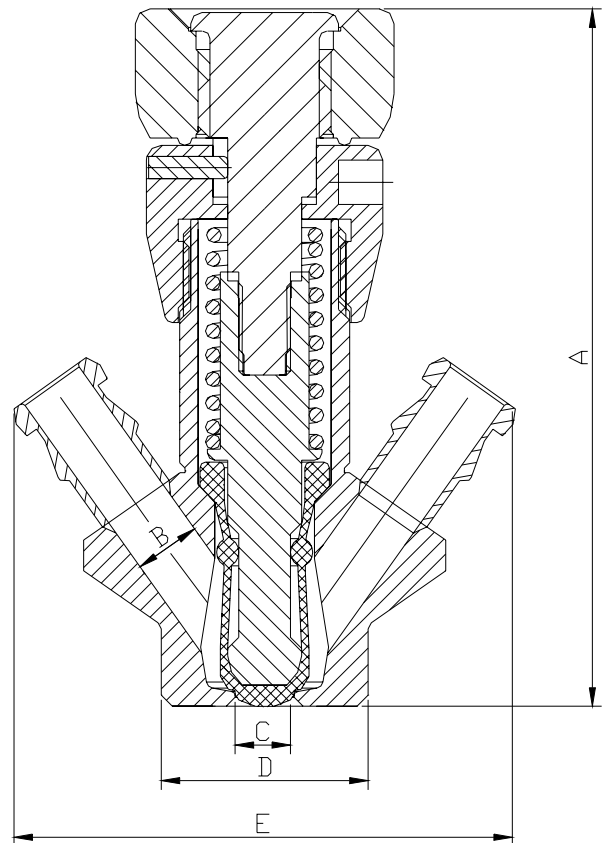

Item no.	Installation	Type	Connection In-/outlet	Dim. D
400001	Welded	T	Quick connection	ø28mm
400004	Welded	T	Thread	ø28mm
400009	Varivent ø68	varivent	Quick connection	ø68mm
400011	Welded	P	Quick connection	ø25mm
400014	Welded	P NW28	Quick connection	ø28mm
400017	Welded	P OD 12x1	Quick connection	Ø10mm inner pipe ⁷
400021	Clamp	C	Quick connection	ø25mm
400022	Clamp	C	Quick connection	Ø50,3mm
400031	Thread	S	Quick connection	M28x1,5

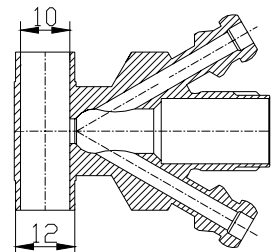

Mounting instructions

Location:

The valve should always be located with its centre line in a horizontal position, and with the two hose pieces in a vertical position as shown in the diagram. The valve will then be self-draining.

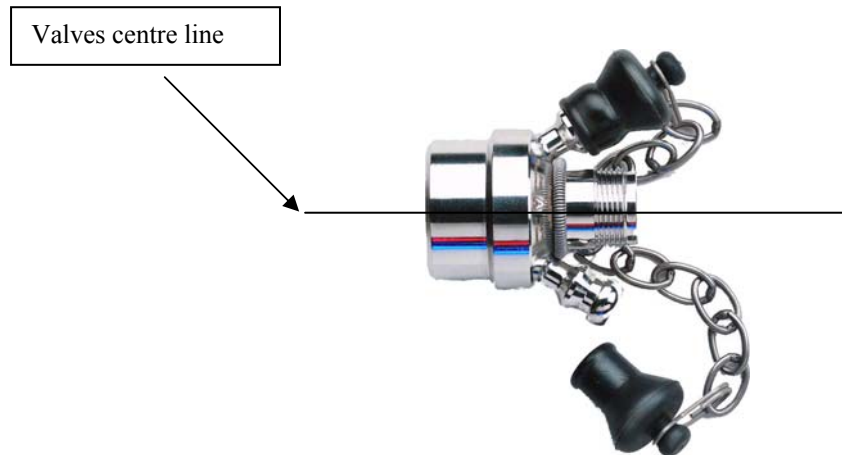

Before welding:

Remember to disassemble the valve body and head. See instructions on page 10.

The valve body and head must be separated during welding. Rubber plugs, chain and membrane must be removed from the valve body, as otherwise heat from the welding process will damage them.

Welding instructions:

Valves for welding are available in two types: T (tank) and P (pipe).

1. For type T (tank) it is necessary to drill a hole $\varnothing 28$ mm into the tank wall, and then fit the valve into this hole flush with the inside of the tank. Welding should be carried out as a penetration welding.
Material thickness less than 4 mm: Weld from inside.
Material thickness greater than 4 mm: Weld from both outside and inside.

Since type T has a solid end piece, the valve will not be damaged by penetration welding. However, the use of purge gas in the form of either Argon or Formier gas is recommended in order to give the best result.



Important! When grinding/polishing the internal weld, the valve seat must not be touched.

2. For type P (pipe) penetration welding must be carried out from outside.

The valve is machined with a recess-like shoulder on the outside of the end piece which gives approximately the same material thickness (1.5mm material thickness) as in the pipe wall. This machined shoulder can be modified according to the customer's wishes.

The welding result will be best if the following method is used:

A collar is made on the pipe section so that the valve has a flat contact face. This flaring must look like a T-piece, as shown in the example below.

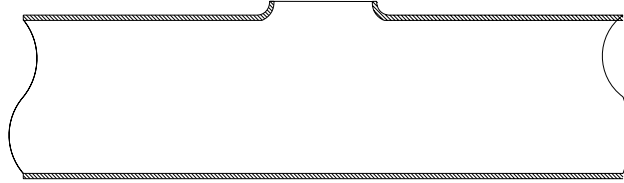

- The pipe section and the valve's hose pieces are sealed with sponge rubber or similar.
- Purge gas such as Argon or Formier gas is fed through the valve body into the pipe section and the system is now filled with 6 times the estimated volume of the pipe section. All O₂ is thus expelled from the system and welding can commence.
- Welding can take place with the purge gas continually flowing in the system.
- The gas remains in the system until the item is lukewarm, after which the set-up can be dismantled.

Guideline welding values:

M4 valve welded onto a 2 mm 3" dairy pipe:	40-50 Amp.
M4 valve welded onto a 1.25 mm 2" dairy pipe:	approx. 30 Amp.

It should be noted that Keofitt can supply all P type valves welded onto a pipe section according to customer specifications. Flaring is thus avoided and only a girth weld is required.

Block diagram for welding to pipe and tank

Keofitt valve type P (pipe):

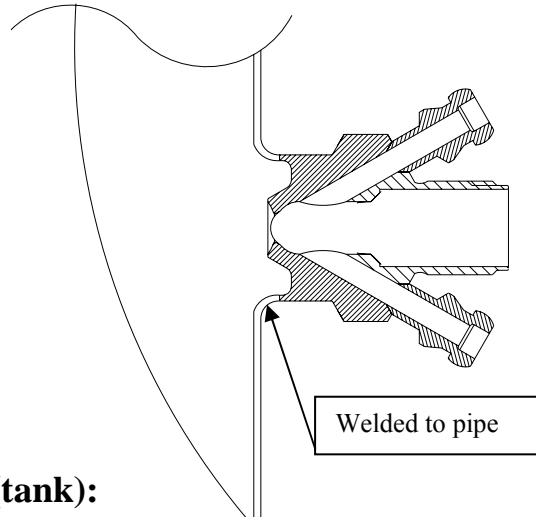

Keofitt valve type T (tank):

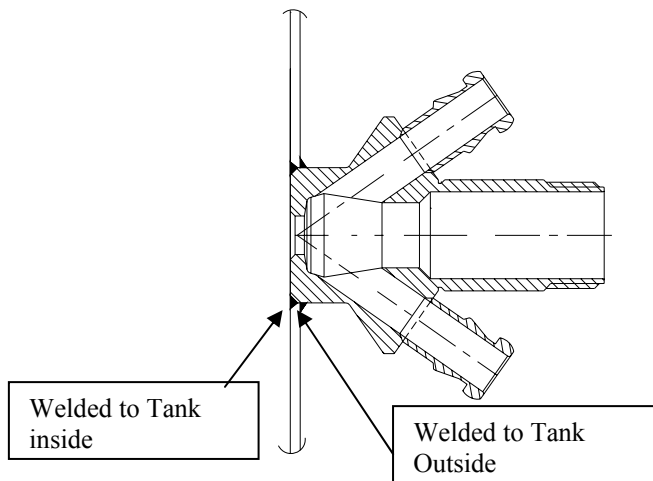

Keofitt valve type P (pipe connection vertical):

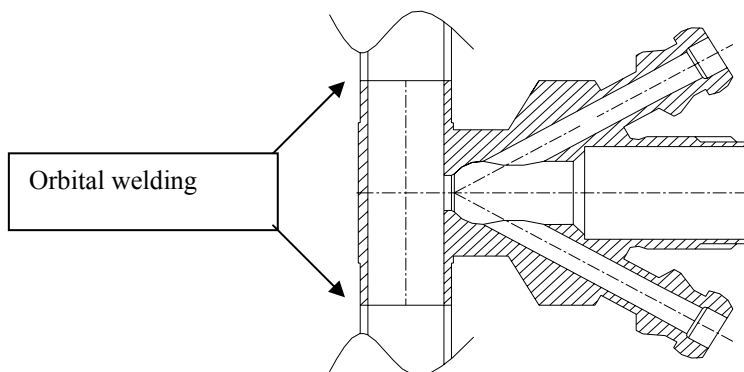

Block diagram for installation with Clamp, Varivent[®] and Thread.

Keofitt valve Clamp connection:

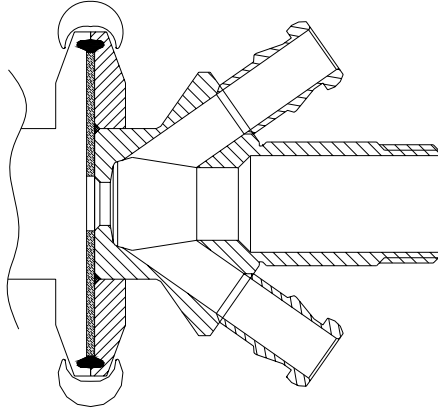

Keofitt valve Varivent[®]:

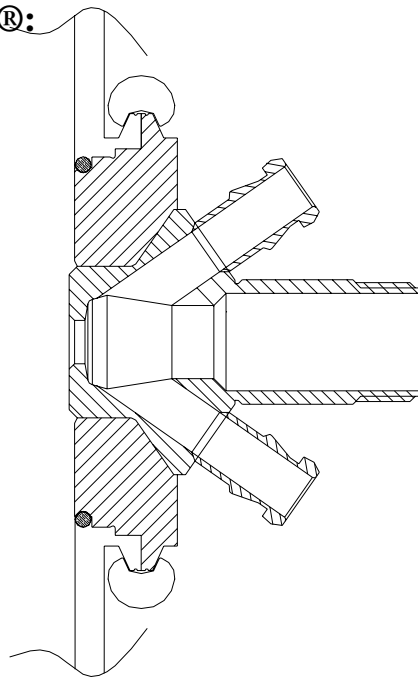

Keofitt valve Thread:

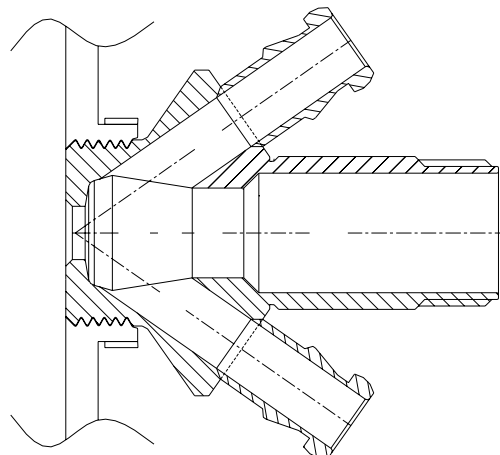

Everyday use of the valve

Warning!: During sterilisation with steam the valve will become hot, and care should thus be taken when handling the valve.



Warning!: The valve is designed for use in working conditions of up to 6 bar and temperatures of up to 121°C. It is therefore important to be aware that the rubber plug (designed for max. 3 bar) or the steel plug (designed for max. 10 bar) can be forced out at high speed if not seated correctly.
Therefore always remember to use safety goggles when taking samples because of the risk to the eyes.

Warning!: For valve heads allowed for Group IIGD, Category 2 (zone 1) both handle and top of valve heads N and Q must be cleaned before use.



Sterilisation:

Remember! Use saturated steam without condensation at max. 2 bar. At higher pressures the membrane can be damaged/split.

The coaxial design ensures absolute cleanliness without the use of CIP or similar. If CIP is used, please refer to enclosed data sheet. If in doubt, contact Keofitt.

Sterilisation takes place with valve closed.

1. Remove the plugs.
2. Connect the steam hose to the valve's upper hose piece.
3. Open the steam supply and let it flow through the valve for sterilisation. 1 min. at 121°C (2 bar).
4. Close the steam supply.



Important! To reach 121°C a pressure of 2 bar(g) is needed. This can only be reached by use of a pressure release valve, or other counter pressure

Important! Let steam hose be in place to prevent air contamination. If removal of steam hose is required, fit a sterile rubber or stainless steel plug onto the upper hose piece.

Sampling:

1. Open the valve and take the sample.
2. Shut the valve after the sample has been taken.
3. Clean the valve with steam and/or hot water, cf. 'sterilisation', points 1-4.

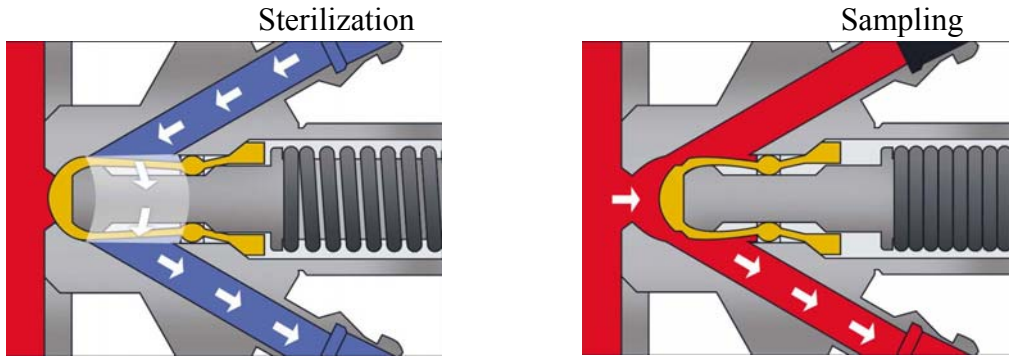

Maintenance:

The membrane must be replaced every second month.

In the event of intensive sterilisation and cleaning it may be necessary to replace it more frequently. For valve heads with Micro Port, approx. 5-10 samples may be drawn off per membrane at 5-2 bar respectively.

The rubber plug must be replaced at least once every six months.

For disassembly of valve body and valve head, see instructions.

Disassembly and assembly of valve body and head:

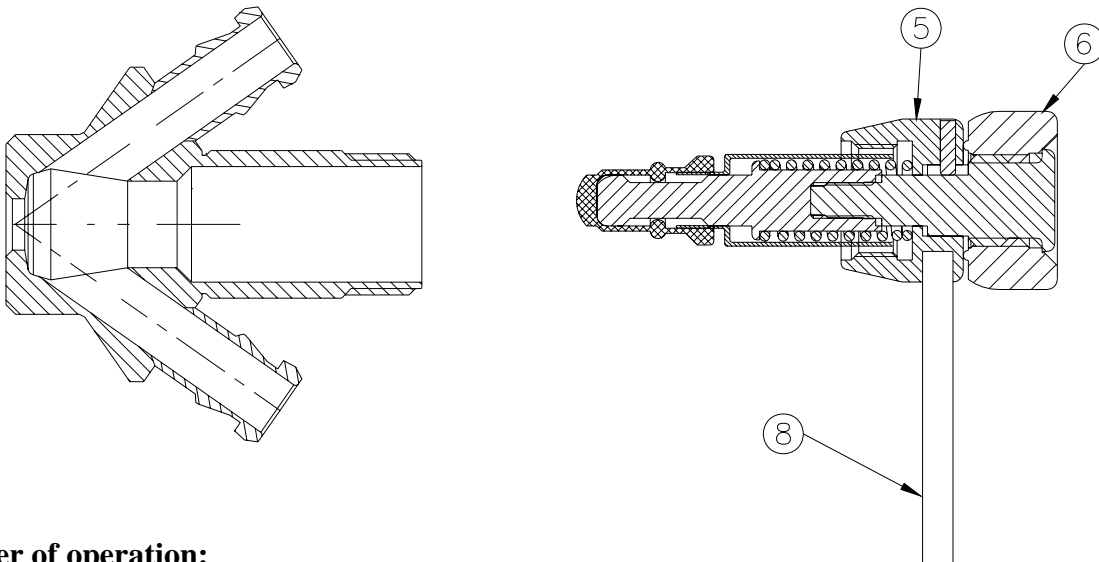

Order of operation:

Remember! - When replacing the membrane, set the valve head in the open position before it is screwed loose and pulled out of the valve body.

1. Set the valve head at the open position. For types h and k this is done by turning pos. 6 clockwise.
2. Remove the valve head pos. 5. A Tommy bar pos. 8 should be used for disassembly and assembly. Carried out by turning pos. 5 anti-clockwise.
3. Refit the valve head (in the open position) once the necessary parts have been replaced.

Instructions on replacing PTFE membrane

1. Open valve.
2. Release clamp ring.
3. Remove the valve head from the valve body.
4. Close valve head.
5. Push the membrane upwards until you can fit tool for membrane under it.
6. Insert tool for membrane, between the membrane and the valve.
7. Close valve head.
8. Now the membrane should loose from the valve head and can be replaced.

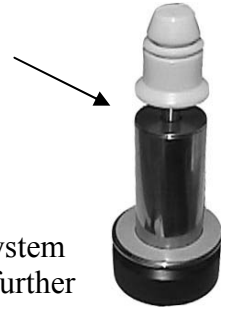

Important: Once the membrane has been removed from the valve head the click system in the membrane might be damaged. Therefore the membrane might be unsafe for further use and it is not recommended to use the membrane again.

To attach new membrane to valve head.

9. Set the valve head to closed position.
10. Place the new membrane on valve head.
11. Press down on membrane, until it clicks in place.
12. Set the valve head in open position.
13. Insert the valve head into the valve body.
14. Attach and close clamp ring.
15. Close valve head.



Important: Do not use hammer or other tool that might scratch the surface of the membrane.

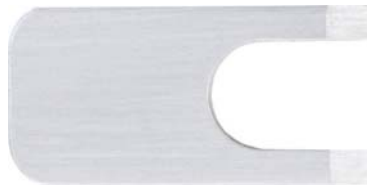

Tool for membrane 400255

Spare parts list:

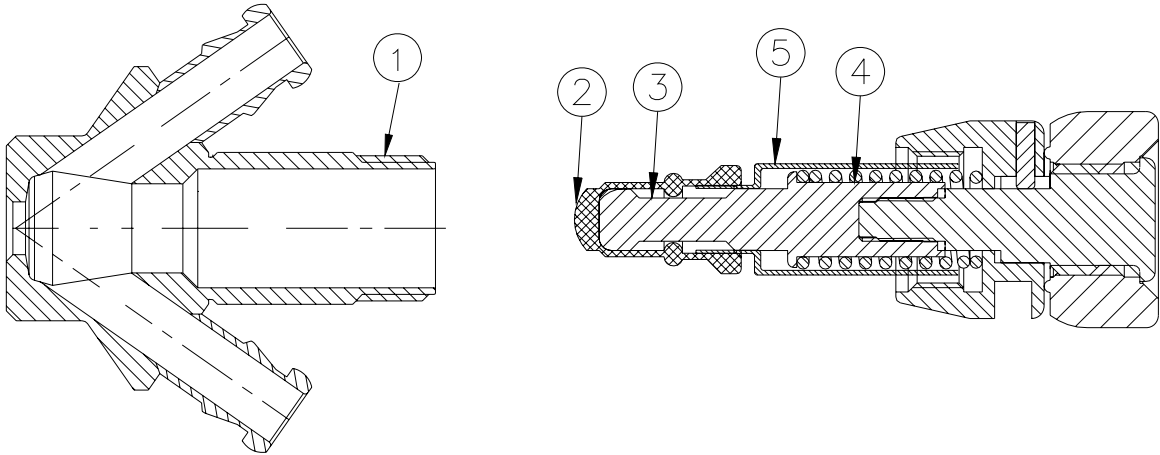

Pos.	Item
1.	Valve body
2.	Membrane Silicone (grey)
	Membrane EPDM (black)
	Membrane PTFE (White)
3.	Lower stem
4.	Spring
5.	Steel bushing

Parts and accessories for M4:

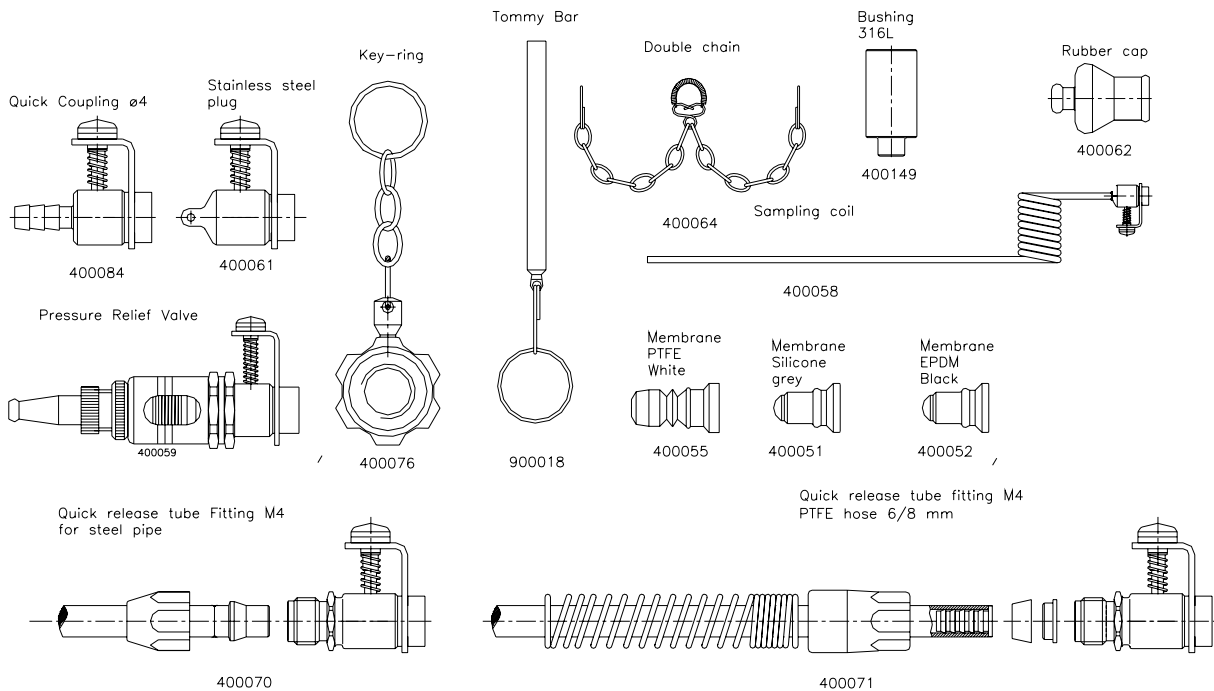

Valve Heads for M4:

Type H, manual operated – item no. 400041.

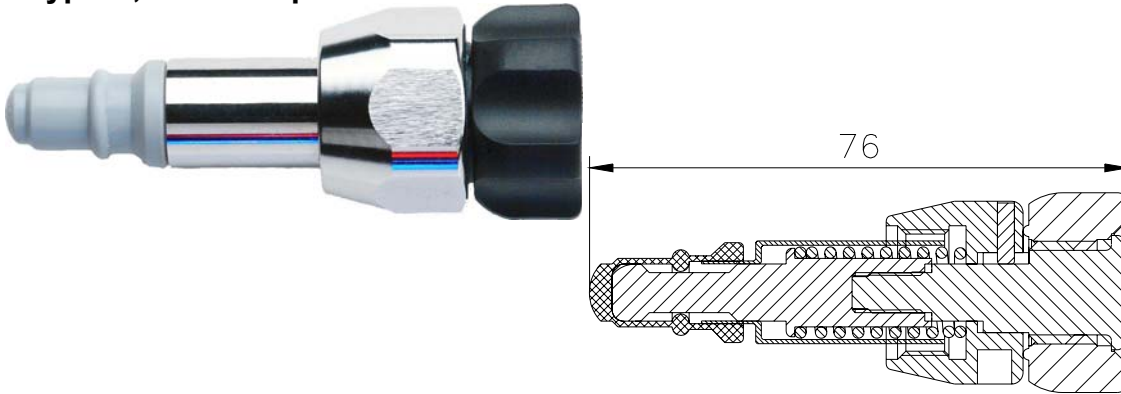

Available with:
 Silicone membrane
 Item no.: 400051
EPDM membrane
 Item no.: 400052
PTFE membrane
 Item no.: 400055
 PTFE Valve item no.:
 405541

Type K, manual operated key version – item no. 400042.

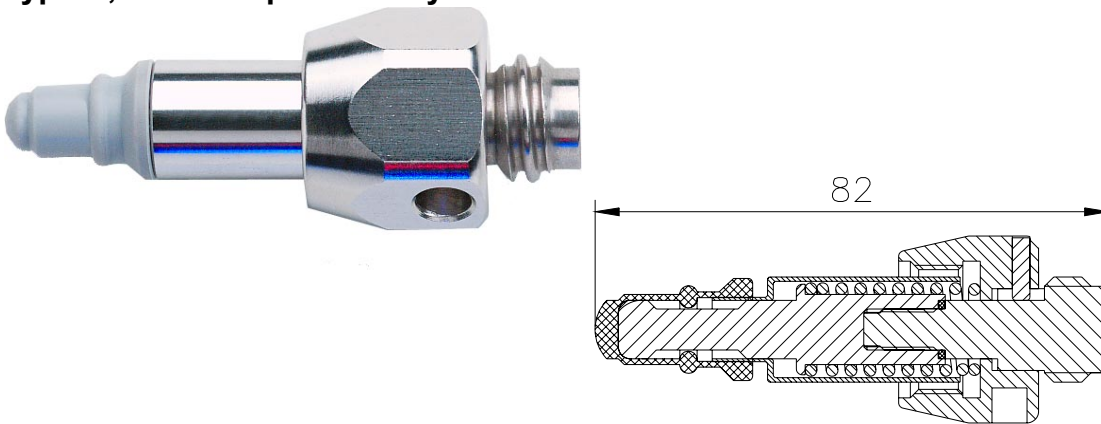

Available with:
 Silicone membrane
 Item no.: 400051
EPDM membrane
 Item no.: 400052
PTFE membrane
 Item no.: 400055
 PTFE Valve item no.:
 405542

Type Q, manual operated with lever – item no. 400043.

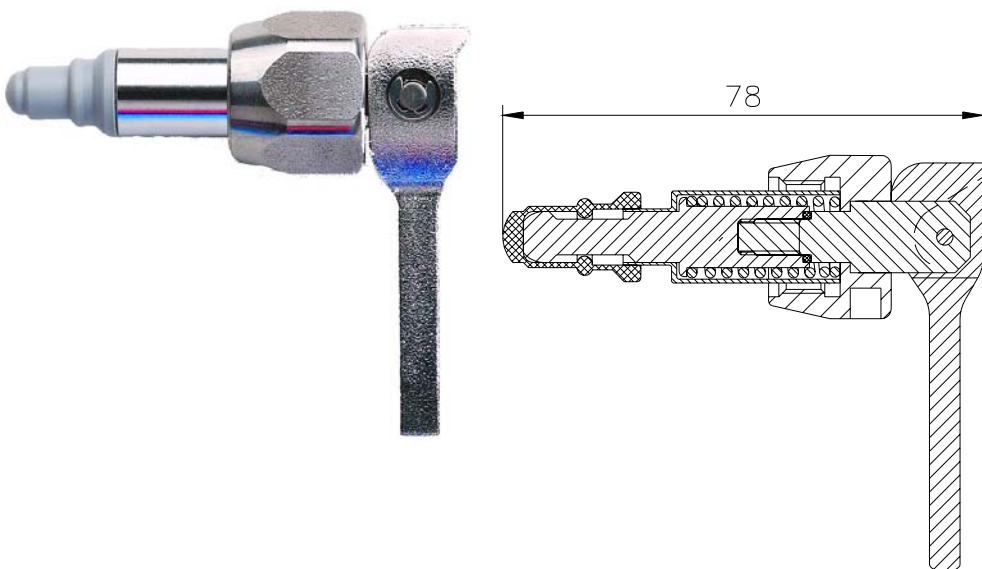

Available with:
 Silicone membrane
 Item no.: 400051
EPDM membrane
 Item no.: 400052
PTFE membrane
 Item no.: 400055
 PTFE Valve item no.:
 405543

Type N, Pneumatically activated – item no. 400044.

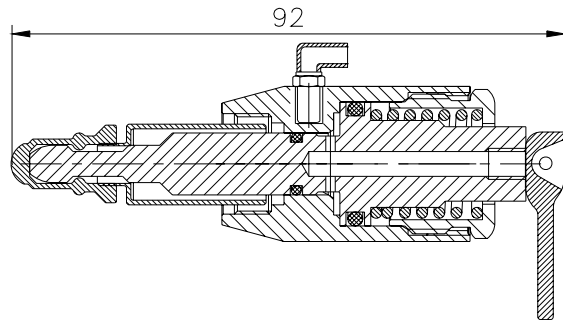

Available with:
Silicone membrane
Item no.: 400051
EPDM membrane
Item no.: 400052
PTFE membrane
Item no.: 400055
PTFE Valve item no.:
405544

Type N, Pneumatically activated key version – item no. 400046.

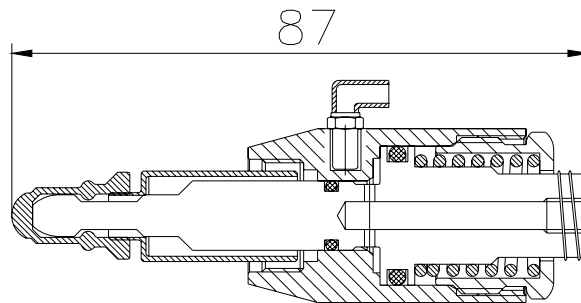

Available with:
Silicone membrane
Item no.: 400051
EPDM membrane
Item no.: 400052
PTFE membrane
Item no.: 400055
PTFE Valve item no.:
405546

Type B, Pressure resistant up to 12 bar(g)– item no. 400047.

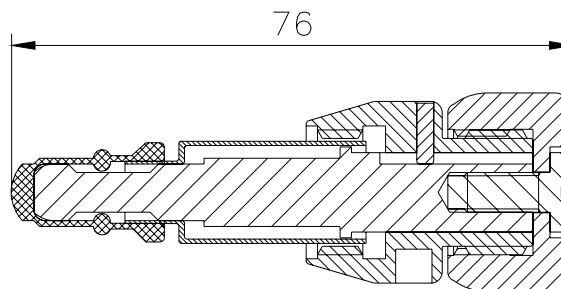
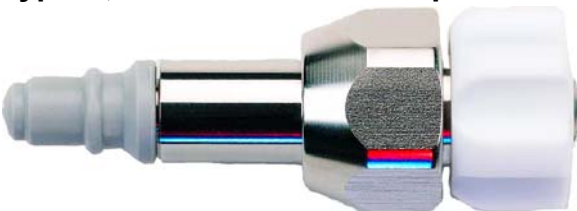

Available with:
Silicone membrane
Item no.: 400051
EPDM membrane
Item no.: 400052
PTFE membrane
Item no.: 400055
PTFE Valve item no.:
405546

Silicone Membranes for M4 – item no. 400051:



Length 16mm

Technical Specification:

Membrane:	400051.
Type:	Silicone (Si, Q)
Colour	Light Grey
Hardness °Sha	60
Tensile strength MPa	10,5
Elongation at break %	530
Density g/cm ³	1.17
Range of temperature in dry atmospheric air °C	-80 - + 200°C
Compression set, DIN 53517, 24h/175°C %	30
Wear resistance	Less suitable (1)
Tear resistance	Very good (3)
Resistance to Weather and Ozone	Excellent (4)
Resistance to Hydrolysis (water and steam)	Good (2-3)
Resistance to Chemicals (acids/bases)	Suitable (2)
Resistance to mineral oil and gas	Less suitable (1)
Air and gas density	Not suitable (0)
Food safe	Yes (FDA*)

*FDA approved compound according to Code of Federal Regulations Title 21 - § 177.2600

Average live time of a silicone membrane is 2-3 months of lasting by normal use means:

Temp. max:.....121⁰C
 Steam pressure max:...2 bar(g)
 Process pressure.....1-6 bar
 Cip.....Nho4 < 3% or similar
 Samples.....1-5 a day

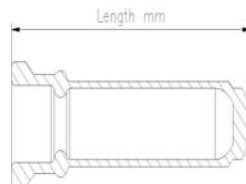

EPDM Membranes for M4 – item no. 400051:



Length 16mm

Technical Specification:

Membrane:	400052.
Type:	EPDM
Colour	Black
Hardness IRHD/ °Sha	61/59
Tensile strength MPa	16
Elongation at break %	400
Density g/cm ³	1.1
Range of temperature in dry atmospheric air °C	-50 - + 140°C
Compression set, DIN 53517, 24h/175°C %	18
Wear resistance	Very good (3)
Tear resistance	Very good (3)
Resistance to Weather and Ozone	Excellent (4)
Resistance to Hydrolysis (water and steam)	Excellent (4)
Resistance to Chemicals (acids/bases)	Very good (3)
Resistance to mineral oil and gas	Not suitable (0)
Air and gas density	Less suitable (1)
Food safe	Yes (FDA*)

*FDA approved compound according to Code of Federal Regulations Title 21 - § 177.2600

Average live time of an EPDM membrane is 2-3 months of lasting by normal use means:

Temp. max:.....121⁰C
 Steam pressure max:...2 bar(g)
 Process pressure.....1-6 bar
 Cip.....Nho4 < 3% or similar
 Samples.....1-5 a day

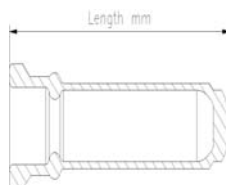

PTFE membrane for M4 valves:



Length 20mm

Technical Specification:

Type:	TFM 1600 PTFE		
Colour	White		
Temperature range	- 200 - +200°C		
Ball hardness		N/mm ²	29
Tensile strength	DIN53455	N/mm ²	35
Elongation at break	DIN53455	%	350
Density	DIN 53479	g/cm ³	2.17
Shore D	DIN 53505		57
Thermal conductivity	W/m.k DIN 57572		0.25-0.5
Expansion Coefficient	DIN 52612		9-12x10 ⁻⁵ K ⁻¹
Friction coefficient	very low (<0.1)		
Flammability	Inflammable UL 94VO		
Chemical resistance	*		
Food safe	Yes (FDA**)		

* Is not attacked by common chemicals, with the exception of strongly oxidising acids.

**FDA approved compound according to Code of Federal Regulations Title 21 - § 177.1550

Keofitt guaranties 1 year of lasting by normal use means:

- Temp.....115-130⁰C
- Steam pressure.....1,5-2,5 bar
- Process pressure....1-6 bar
- Cip.....Nho4 < 3% or similar
- Samples.....1-5 a day

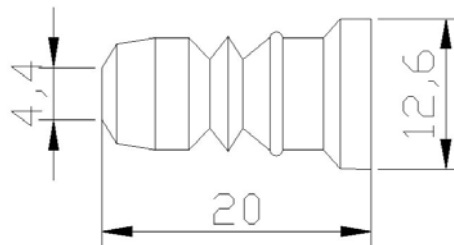

Parts Needed to change from Silicone to PTFE
400340
400055

Upgrade from silicone to PTFE membrane:

For manually operated valve heads type H, K and Q:

To assemble see manual on WWW.Keofitt.dk under “MN-000000 replacing silicone for PTFE Membrane”

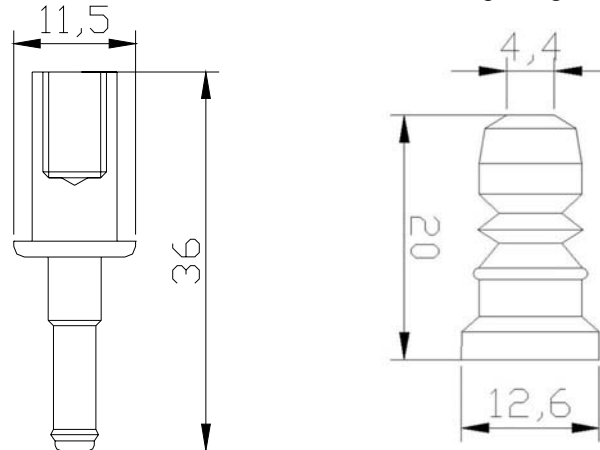

Nr.	Part Nr.	Part name	material	Nr.	Part Nr.	Part name	material
1	400340	Lower stem for PTFE	AISI 316L	2	400055	Membrane for M4	PTFE

For Pneumatically activated valve heads type N:

To assemble contact Keofitt at Keofitt@keofitt.dk or by phone.

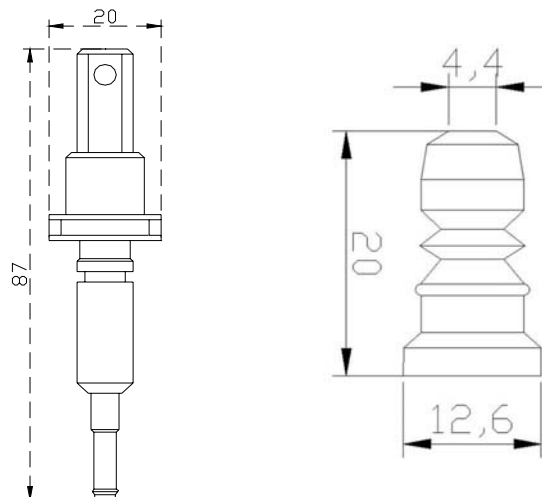

Nr.	Part Nr.	Part name	material	Nr.	Part Nr.	Part name	material
1	400345	Spindle for M4	AISI 316L	3	600825	O-ring 7,1x1,6	EPDM
2	400055	Membrane for M4	PTFE	4	400820	O-ring 15,3 x 2,4	EPDM

Update:

For complete set of updated data sheets for all M4 valve bodies and heads please refer to our web page www.keofitt.dk

www.keofitt.dk