

User manual for W25 sampling valve



Contents:

Contents:	1
Introduction:	2
Presentation:	2
Restrictions:.....	2
Valve function	2
Mounting instructions	4
Location:.....	4
Before welding:	4
Welding instructions:.....	4
Type T:	4
Block diagram for installing W25 valve.	5
Keofitt valve type T (tank):	5
Everyday use of the valve	6
Sterilisation:.....	6
Sampling:	6
Maintenance:.....	7
Instructions on replacing PTFE membrane:	7
Available valve heads:	8
Item no. 875547 - Valve Head for W25 Type B:	8
Item no.: 865544 - Valve Head for W15 Type N	8
Membrane for W25 – item no. 870055.....	9
Technical Specification:	9
Update:.....	10

Introduction:

Manufacturer: Keofitt a/s,
Hans Egedes Vej 19
5210 Odense NV
Denmark

Sampling valve, Type: W25
Year of production: 2002

Presentation:

The Keofitt sampling valve is a valve which can be readily sterilised and which meets both hygienic and production requirements. This means that an effective cleaning and sterilisation of the sampling valve can be carried out between random samples independently of the course of the production process.

The Keofitt W25 valve is 3-A certified. 3-A Sanitary Standard is an American standard which is normative for a component's ease of cleaning and sterilisation. The standard ensures optimum conditions for food products which may come into contact with the component in question.

The valve is used in a wide range of business areas where sampling high viscosity products, such as dairies, yogurt, fruit and marmalade industries.



Warning! During sterilisation with steam the valve will become hot, and care should thus be taken when handling the valve.

Restrictions:

- The valve cannot be used for vacuum since the membrane will be sucked hard into the seat.
- The W15 and W25 valves are only available with PTFE membranes.
- The PTFE membrane resists most CIP fluids and very high steam temperatures.
- W25 is only available with Clamp on the inlet /outlet connections.
- For best results it is best to leave the steam hose constantly connected to the valve. Detaching the hose risks air contamination and makes the sterilisation process unnecessarily complicated.

Valve function

The valve is designed to regularly take representative random samples in the production process. The valve is therefore designed such that effective cleaning, sterilisation and sampling can be carried out regularly without interrupting the production process.

Sterilisation is carried out by supplying steam through the upper of the valve's two hose pieces. It is the perfect, hygienic design in the inner part of the valve which enables absolute sterilisation in a closed state.

Note! The membrane functions both as a dynamic packing in the valve seat and as a hygienic, static packing against the valve body.

Item no.: 870001, Valve Body for W25, Type T

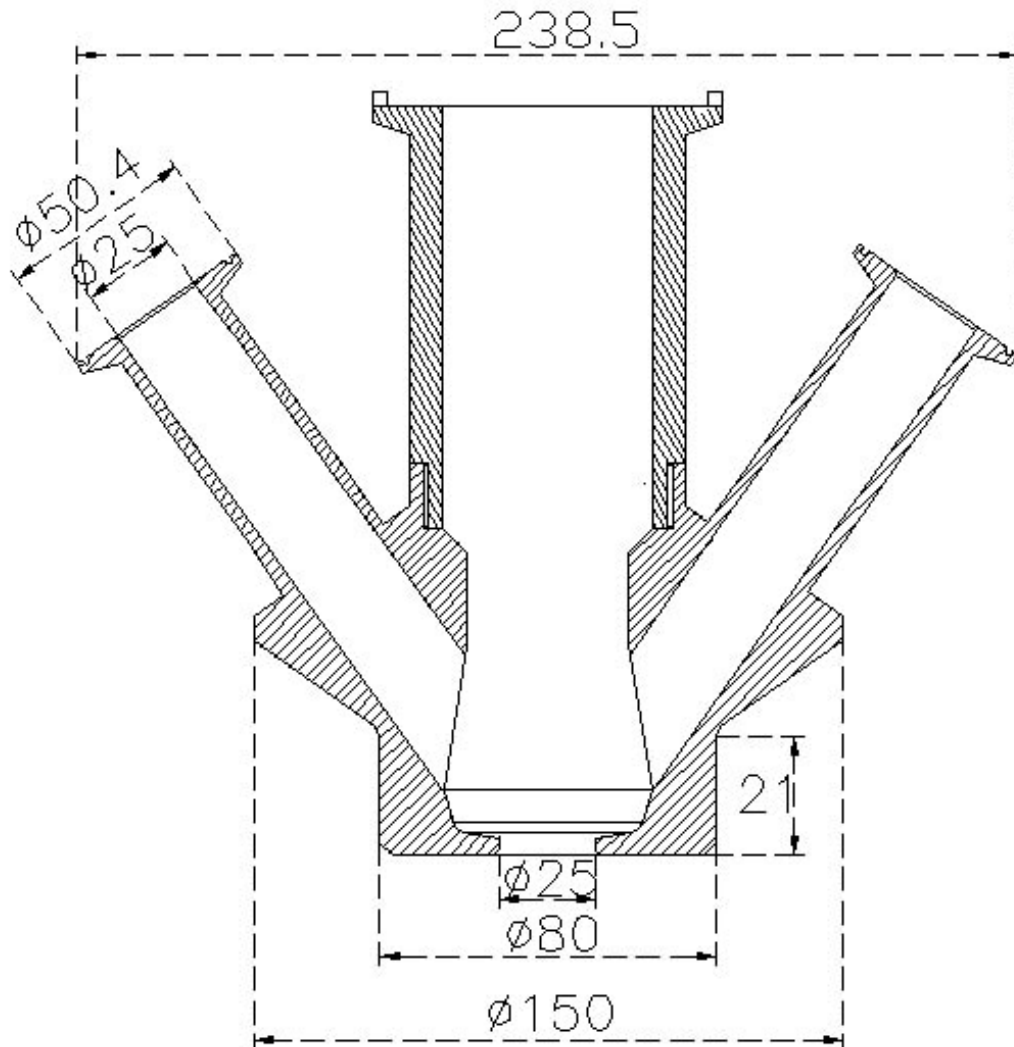

Where to use:

Use for:

Material:

Inner surface:

How to use:

Max. Working pressure:

Outlet diameter:

Net weight:

Welded on tank.

Sample marmalade, yoghurt, fruit and other high viscosity products products.

AISI 316L (1,4404)

Ra 0,8m

Manually or pneumatically operated.

0 - 6 bar (g)

25mm

7,055 kg./pc.

3A certificate

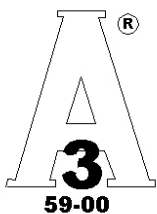

Mounting instructions

Location:

The valve should always be located with its centre line in a horizontal position, and with the two hose pieces in a vertical position as shown in the diagram. The valve will then be self-draining.

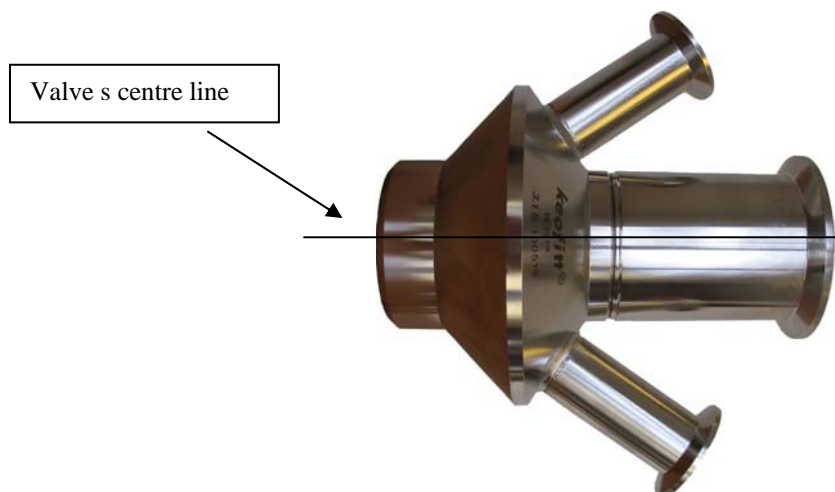

Before welding:

Remember to disassemble the valve body and head.

The valve body and head must be separated during welding plugs membrane must be removed from the valve body, as otherwise heat from the welding process will damage them.

Welding instructions:

Type T:

For type T (tank) it is necessary to drill a hole $\varnothing 80$ mm into the tank wall, and then fit the valve into this hole flush with the inside of the tank. Welding should be carried out as a penetration welding.

Material thickness less than 4 mm:

Weld from inside.

Material thickness greater than 4 mm:

Weld from both outside and inside.



Important! When grinding/polishing the internal weld, the valve seat must not be touched.

Block diagram for installing W25 valve.

Keofitt valve type T (tank):

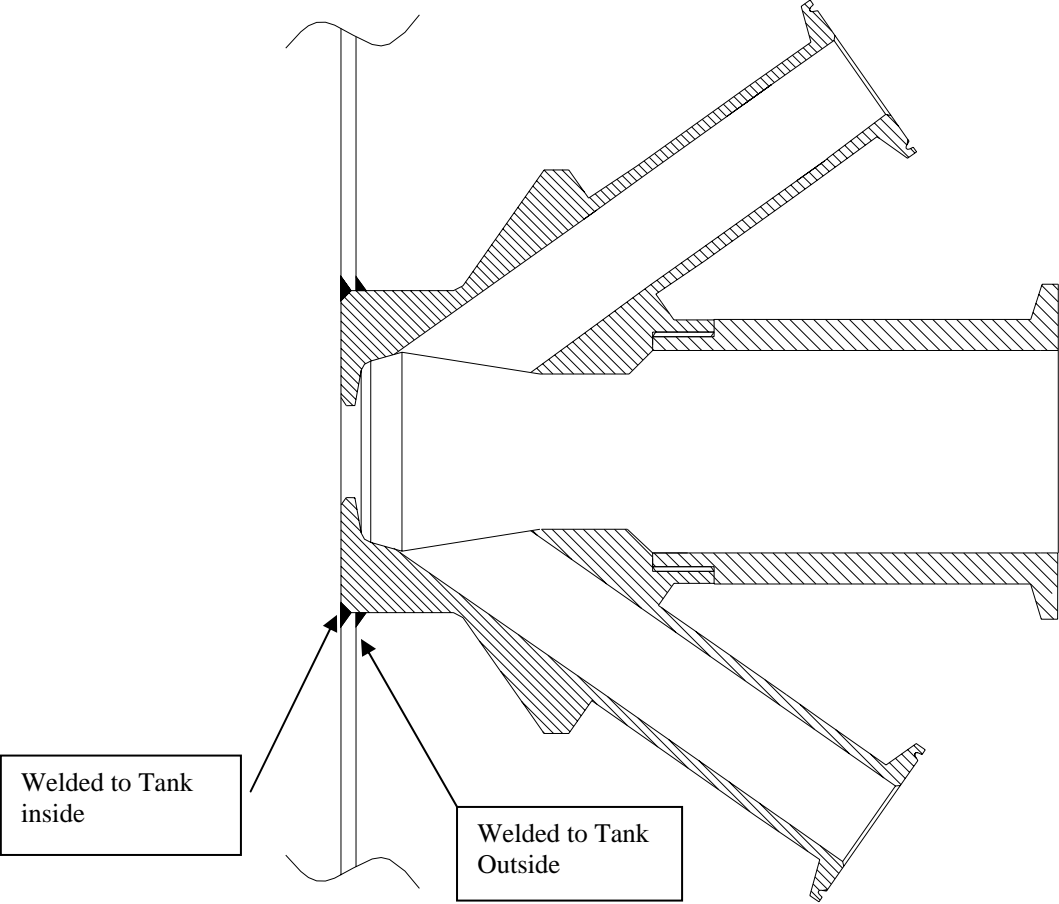

Everyday use of the valve

Warning! During sterilisation with steam the valve will become hot, and care should thus be taken when handling the valve.

Warning!: For valve heads allowed for Group IIGD, Category 2 (zone 1) both handle and top of valve heads N and Q must be cleaned before use.



Sterilisation:

Remember! Use saturated steam without condensation at max. 2 bar(g). At higher pressures the membrane can be damaged/split.

The coaxial design ensures absolute cleanliness without the use of CIP or similar. If CIP is used, please refer to enclosed data sheet. If in doubt, contact Keofitt.

For best results it is best to leave the steam hose constantly connected to the valve. Detaching the hose risks air contamination and makes the sterilisation process unnecessarily complicated.

Important: Sterilisation takes place with valve closed.

1. Open the steam supply 121°C (2 bar(g)).
2. Let the steam flow through the valve for sterilisation. 1 min.
3. Close the steam supply.

Sampling:

1. Sterilise the valve.
2. Open the valve and take the sample.
3. Shut the valve after the sample has been taken.
4. Clean the valve with steam and/or hot water, cf. 'sterilisation', points 1-3.

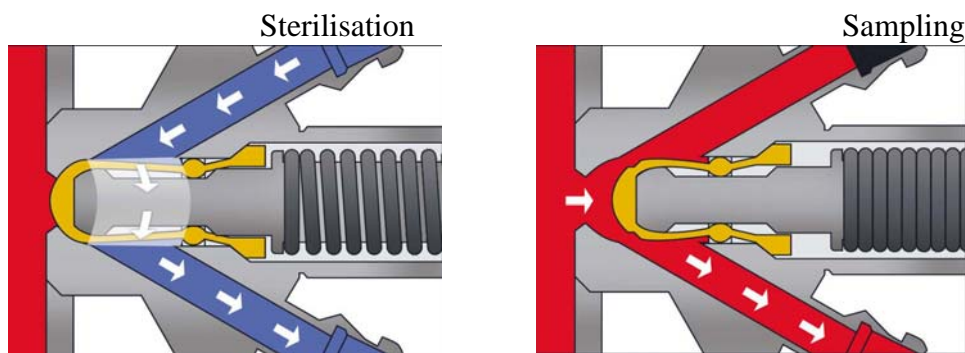

Maintenance:

The membrane must be replaced once every year with terms of average use.

In the event of intensive use, sterilisation and cleaning it may be necessary to replace it more frequently.

Average use means:

Temp.....115-130⁰C

Steam pressure.....1,5-2,5 bar

Process pressure....1-6 bar

Cip.....Nho4 < 3% or similar

Samples.....1-5 a day

Instructions on replacing PTFE membrane:

1. Open valve.
2. Release clamp ring.
3. Remove the valve head from the valve body.
4. Close valve head.
5. Push the membrane upwards until it is stuck in compressed mode.
6. Insert tool for membrane, between the membrane and the valve.
7. Close valve head.
8. Now the membrane should loose from the valve head and can be replaced.



Important: Once the membrane has been removed from the valve head the click system in the membrane might be damaged. Therefore the membrane might be unsafe for further use and it is not recommended to use the membrane again.

To attach new membrane to valve head.

9. Set the valve head to closed position.
10. Place the new membrane on valve head.
11. Press down on membrane, until it clicks in place.
12. Set the valve head in open position.
13. Insert the valve head into the valve body.
14. Attach and close clamp ring.
15. Close valve head.

Important: Do not use hammer or other tool that might scratch the surface of the membrane.



Tool for membrane item no. 870255

Available valve heads:

Item no. 875547 - Valve Head for W25 Type B:

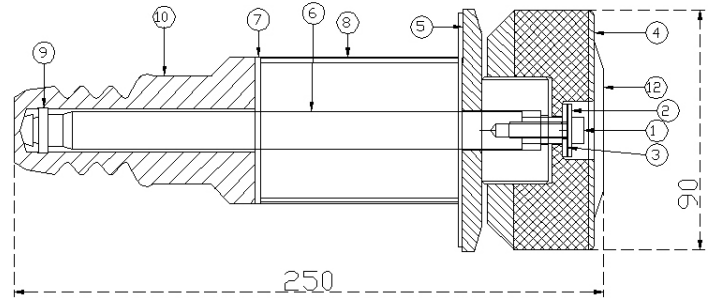

Nr	Part Nr.	Part name	material	Nr	Part Nr.	Part name	material
1	509000	Screw 5x8	AISI 316L	7	870449	Disc for membrane W25	AISI 304
2	870359	Disc for stop	AISI 304	8	870149	Bushing for W25	AISI 304
3	870459	Disc for top	AISI 304	9	870349	Pressure disc for W25	AISI 304
4	870341	Handle for W25	PEHD	10	870055	Membrane for W25	PTFE
5	870241	Thread for handle	AISI 304	11	900187	Clamp ring for W25	St. St.
6	870140	Stem for W25	AISI 316L	12	870441	Cover for handle	AISI 303

Item no.: 865544 - Valve Head for W15 Type N

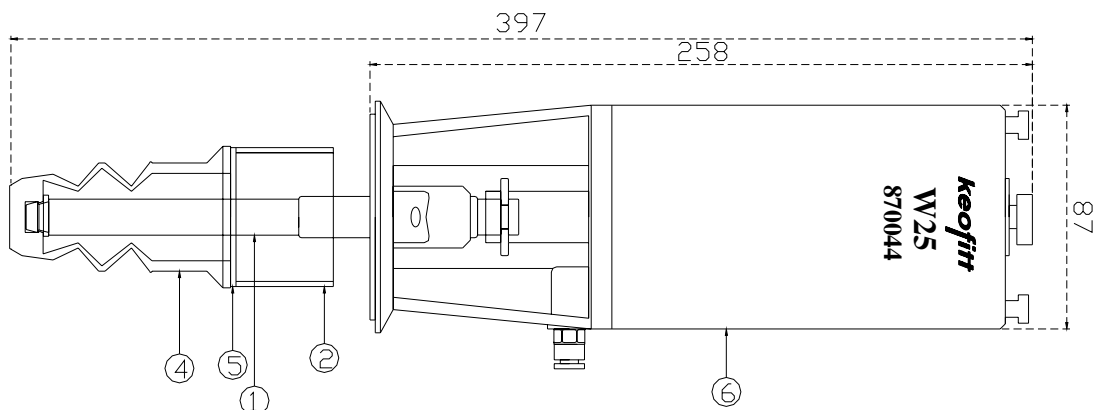

Nr	Part Nr.	Part name	material	Nr	Part Nr.	Part name	material
1	870141	Lower stem for W25	AISI 304	5	870449	Disc for membrane	AISI 304
2	870148	Bushing for W25	AISI 304	6	870144	Actuator W25 SRC	Stand. SRC
3	870248	Neck for W25			900186	Clamp ring for W25	AISI 304
4	870055	Membrane for W25	PTFE				

Membrane for W25 – item no. 870055.

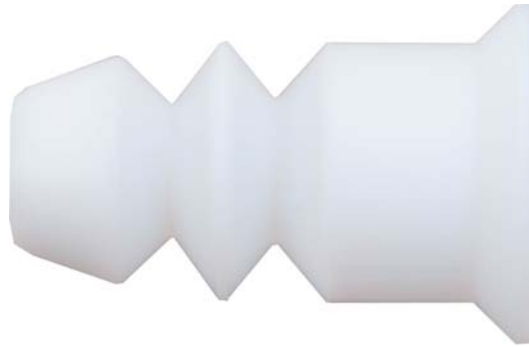

Technical Specification:

Type:	AF1012 PTFE		
Colour	White		
Temperature range	- 200 - +200°C		
Ball hardness		N/mm ²	29
Tensile strength	DIN53455	N/mm ²	35
Elongation at break	DIN53455	%	350
Density	DIN 53479	g/cm ³	2.17
Shore D	DIN 53505		57
Thermal conductivity	W/m.k DIN 57572		0.25-0.5
Expansion Coefficient	DIN 52612		9-12x10 ⁻⁵ K ⁻¹
Friction coefficient	very low (<0.1)		
Flammability	Inflammable UL 94VO		
Chemical resistance	*		
Food safe	Yes (FDA**)		

* Is not attacked by common chemicals, with the exception of strongly oxidising acids.

**FDA approved compound according to Code of Federal Regulations Title 21 - § 177.1550

Keofitt guaranties 1 year of lasting by normal use means.

Temp.....115-130⁰C
 Steam pressure.....1,5-2,5 bar
 Process pressure....1-6 bar
 Cip.....Nho4 < 3% or similar
 Samples.....1-5 a day

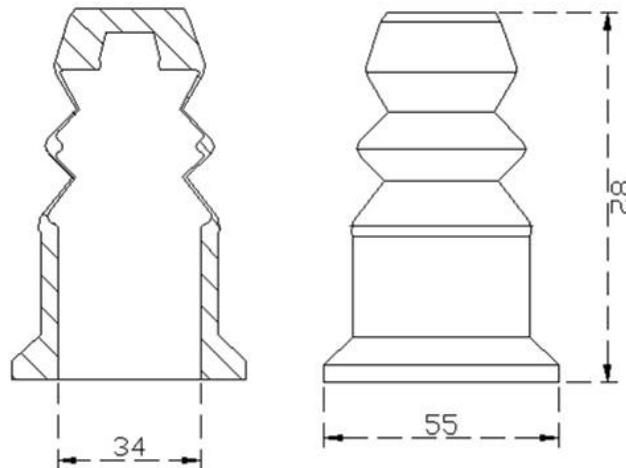

Update:

For complete set of updated data sheets for all W25 valve bodies and heads please refer to our web page www.keofitt.dk

www.keofitt.dk