

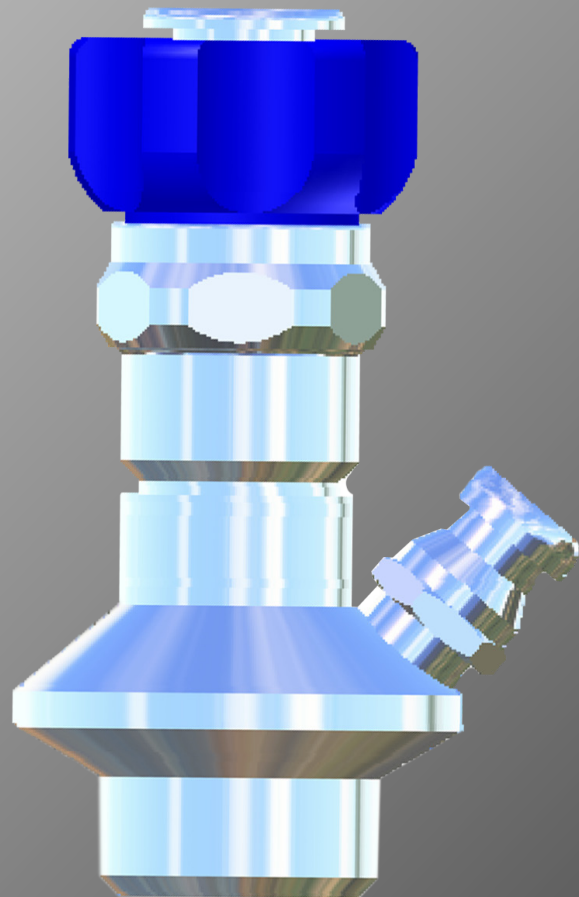

WORLD LEADERS IN STERILE SAMPLING™

KEOFITT SIMPLEX™ SAMPLING VALVE

USER MANUAL



SOME PEOPLE WOULDN'T GAMBLE WITH THEIR SAMPLE™

INTRODUCTION:

MANUFACTURER: Keofitt a/s,
Lumbyvej 11H
5000 Odense C
Denmark

TYPE: KEOFITT SIMPLEX™ SAMPLING VALVE

YEAR OF INTRODUCTION: 2007

YEAR OF REVISED DESIGN: 2009

CONTENTS

Presentation.....	7
Valve function.....	7
Everyday use of the valve	8
Cleaning	8
Sampling.....	8
Technical Data	9
Material	9
Certificate.....	9
Pressure - max.	9
Surface finish.....	9
Viscosity:	9
Keofitt Simplex valves - MANUAL VALVES	10
Keofitt Simplex valves - PNEUMATIC VALVES.....	11
Parts and accessories for Keofitt Simplex™	12
Mounting instructions.....	13
Location:.....	13
Before welding:	13
Welding instructions	13
Maintenance.....	14
Spare parts list	14
Disassembly and assembly of valve body and head.....	14

PRESENTATION

The Keofitt Simplex sampling valve is a valve which can be readily sanitized and which meets both hygienic and process design requirements. This means that an effective cleaning of the sampling valve can be carried out between production batches. The Keofitt Simplex valve is EHEDG Type EI authorised. The EHEDG Type EI certification is a European standard and it includes additional tests of bacterial increase on components that are in direct contact with the sample after the CIP process. The valve is used in a wide range of processing industries, such as breweries, dairies, and the pharmaceutical and biotechnological industries.

VALVE FUNCTION

The valve is designed to regularly take representative non-sterile random samples in the production process. The valve is therefore designed such that effective cleaning and sampling can be carried out. For sterile sampling, please refer to other Keofitt products such as Keofitt W9 and Keofitt Reflex.

Cleaning is carried out by simply opening the valve during the CIP process allowing the cleaning agents (???) to flow through the valve and its outlet which should be connected to a by-pass loop or other closed circuit to prevent the operator to be exposed to the CIP.

Note! The membrane functions both as a dynamic packing in the valve seat and as a hygienic, static packing against the valve body.



WARNING!

- The valve is designed for use in working conditions of up to 6 bar(g) pressure and temperatures of up to 121 °C. It is therefore important to be aware that the rubber plug (designed for max. 3 bar(g)) or the steel plug (designed for max. 10 bar(g)) can be forced out at high speed if not seated correctly.
- Always remember to use safety goggles when taking samples because of the risk to the eyes.



IMPORTANT!

- The valve cannot be used for vacuum since the membrane will be sucked hard into the seat.
- The membranes are available in three different qualities: silicone, EPDM and PTFE.
- The silicone membrane has the advantage that it in general can stand higher temperatures, but it cannot tolerate moisture condensation resulting from steam sterilisation.
- The EPDM membrane is better able to cope with condensation in the steam, and at the same time can be used with a majority of CIP fluids.
- The PTFE membrane resists most CIP fluids and very high steam temperatures.

EVERYDAY USE OF THE VALVE

Cleaning

Cleaning takes place with valve opened.

1. Remove the plug.
2. Connect the CIP bypass loop to the valve's outlet.
3. Open the CIP supply and let it flow through the valve for cleaning.
4. Close the valve after CIP water rinse.
5. Disconnect CIP bypass loop connection.



WARNING!

- The valve is designed for use in working conditions of up to 6 bar(g) and temperatures of up to 121°C. It is therefore important to be aware that the rubber plug (designed for max. 3 bar(g)) or the steel plug (designed for max. 10 bar(g)) can be forced out at high speed if not seated correctly. Therefore always remember to use safety goggles when taking samples because of the risk to the eyes.
- For valve heads allowed for Group IIGD, Category 2 (zone 1) both handle and top of valve heads N and Q must be cleaned before use.



IMPORTANT!

- CIP fluids are hazardous.

Sampling

1. Open the valve and take the sample.
2. Shut the valve after the sample has been taken.

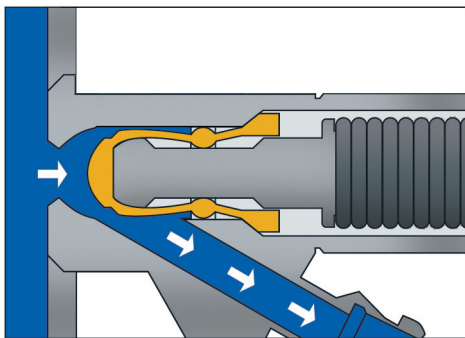

Sampling

TECHNICAL DATA

Material

Valve body:	AISI 316L (1.4404)
Valve head:	AISI 316L (1.4404)
Membrane:	Silicone (grey) EPDM (black) PTFE (white)

Certificate

Valve body:	3.1
Membrane silicone	acc. to FDA & BGA
Membrane EPDM	acc. to FDA & BGA
Membrane PTFE	acc. to FDA & BGA



Pressure - max.

Working pressure:	6 bar(g) / 87 psi(g)
Rubber plug	3 bar(g) / 44 psi(g)
Steel plug	10 bar(g) / 145 psi(g)

Surface finish

Internal:	Ra ≤ 0,8 µm / 32 µinch
-----------	------------------------

Viscosity:

Viscosity range:	0-1000cP, with particles up to 3mm in diameter.
------------------	---



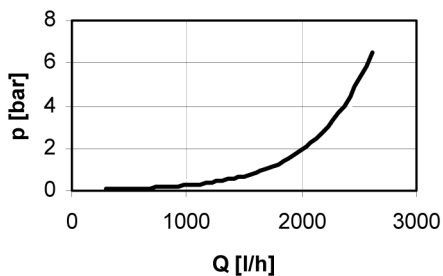







Water at 20°C/68°F



$$K_v = Q \sqrt{\frac{p}{1000 * \Delta p}}$$

- Kv: Valve capacity [m3/h]
- Cv: Valve capacity [USgal/min]
- Q: • Flow through valve seat [m3/h]
- p: • Viscosity of fluid [kg/m3]
- p: • Pressure drop across valve [bar]

KEOFITT SIMPLEX VALVES - MANUAL VALVES

	Silicone				EPDM				PTFE			
Tank welding (type T) - process connection Key measurements (Please refer to bottom page!)	 830141				 830141EPDM				 830141PTFE			
	A	B	C	D	A	B	C	D	A	B	C	D
	7 mm	14 mm	28 mm	8 mm	7 mm	14 mm	28 mm	8 mm	7 mm	14 mm	28 mm	8 mm
Pipe welding (type P) - process connection Key measurements (Please refer to bottom page!)	 831141				 831141EPDM				 831141PTFE			
	A	B	C	D	A	B	C	D	A	B	C	D
	7 mm	14 mm	25 mm	8 mm	7 mm	14 mm	25 mm	8 mm	7 mm	14 mm	25 mm	8 mm
Clamp - connection 1/2" - process connection Key measurements (Please refer to bottom page!)	 832141				 832141EPDM				 832141PTFE			
	A	B	C	D	A	B	C	D	A	B	C	D
	7 mm	14 mm	25 mm	8 mm	7 mm	14 mm	25 mm	8 mm	7 mm	14 mm	25 mm	8 mm
Clamp - connection 1" - process connection Key measurements (Please refer to bottom page!)	 832241				 832241EPDM				 832241PTFE			
	A	B	C	D	A	B	C	D	A	B	C	D
	7 mm	14 mm	50.5 mm	8 mm	7 mm	14 mm	50.5 mm	8 mm	7 mm	14 mm	50.5 mm	8 mm

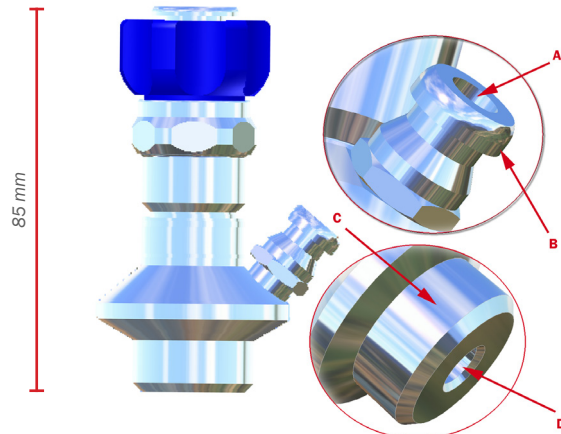



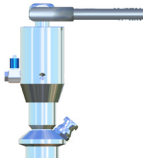
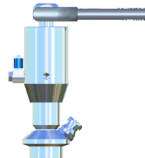
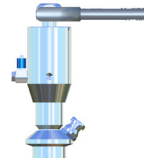
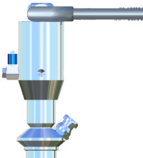
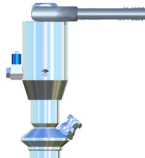
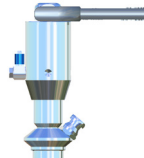
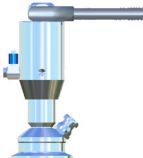
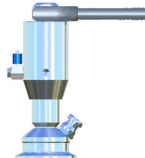
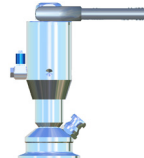

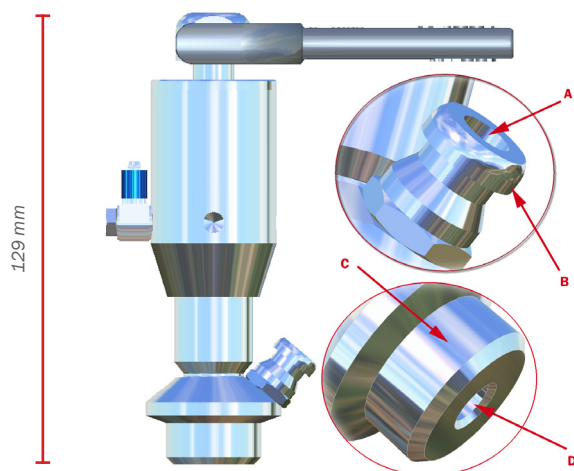
KEOFITT SIMPLEX VALVES - PNEUMATIC VALVES

	Silicone				EPDM				PTFE			
Tank welding (type T) - process connection Key measurements (Please refer to bottom page!)	 810144				 810144EPDM				 810144PTFE			
	A	B	C	D	A	B	C	D	A	B	C	D
	7 mm	14 mm	28 mm	8 mm	7 mm	14 mm	28 mm	8 mm	7 mm	14 mm	28 mm	8 mm
Pipe welding (type P) - process connection Key measurements (Please refer to bottom page!)	 811144				 811144EPDM				 811144PTFE			
	A	B	C	D	A	B	C	D	A	B	C	D
	7 mm	14 mm	25 mm	8 mm	7 mm	14 mm	25 mm	8 mm	7 mm	14 mm	25 mm	8 mm
Clamp - connection 1" - process connection Key measurements (Please refer to bottom page!)	 812144				 812144EPDM				 812144PTFE			
	A	B	C	D	A	B	C	D	A	B	C	D
	7 mm	14 mm	50,5 mm	8 mm	7 mm	14 mm	50,5 mm	8 mm	7 mm	14 mm	50,5 mm	8 mm

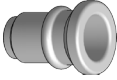
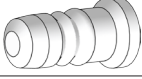

PARTS AND ACCESSORIES FOR KEOFITT SIMPLEX™

	Item	Material	Ident no.	Remark
	Membrane EPDM black	EPDM	600052	
	Membrane silicone grey	Silicone	600051	
	Membrane teflon	Teflon	850055	
	Outlet welding end	316	830107	
	Outlet with mini tri clamp	316	830121	
	O-ring	Silicone	600825	

MOUNTING INSTRUCTIONS

Location:

The valve should always be located with its centre line in a horizontal position, and with the two hose pieces in a vertical position as shown in the diagram. The valve will then be selfdraining.

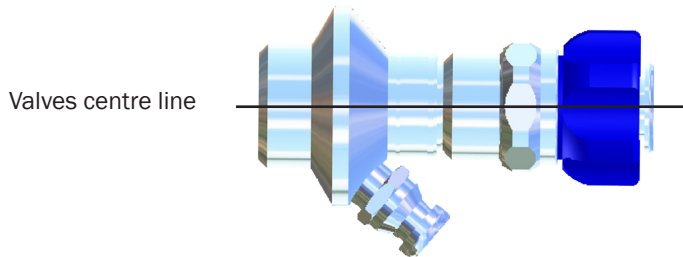

Before welding:

Remember to disassemble the valve body and head. The valve body and head must be separated during welding. Rubber plugs, chain and membrane must be removed from the valve body, as otherwise heat from the welding process will damage them.

WELDING INSTRUCTIONS

Valves for welding are available in two types: T (tank) and P (pipe).

1. For type T (tank) it is necessary to drill a hole $\varnothing 28$ mm into the tank wall, and then fit the valve into this hole flush with the inside of the tank. Welding should be carried out as a penetration welding.
Material thickness less than 4 mm: Weld from inside. Material thickness greater than 4 mm: Weld from both outside and inside.
Since type T has a solid end piece, the valve will not be damaged by penetration welding. However, the use of purge gas in the form of either Argon or Formier gas is recommended in order to give the best result.
2. For type P (pipe) penetration welding must be carried out from outside. The valve is machined with a recess-like shoulder on the outside of the end piece which gives approximately the same material thickness (1.5mm material thickness) as in the pipe wall.



IMPORTANT!

- When grinding/polishing the internal weld, the valve seat must not be touched.

The welding result will be best if the following method is used:

A collar is made on the pipe section so that the valve has a flat contact face. This flaring must look like a T-piece, as shown in the example below.

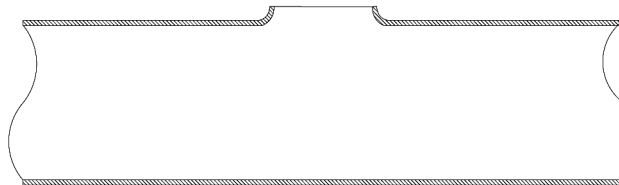

- The pipe section and the valve's hose piece are sealed with sponge rubber or similar.
- Purge gas such as Argon or Formier gas is fed through the valve body into the pipe section and the system is now filled with 6 times the estimated volume of the pipe section. All O₂ is thus expelled from the system and welding can commence.
- Welding can take place with the purge gas continually flowing in the system.
- The gas remains in the system until the item is lukewarm, after which the set-up can be dismantled.

Guideline welding values:

Keofitt Simplex™ valve welded onto a 2 mm 3" dairy pipe: 50-60 Amp.

It should be noted that Keofitt can supply all P type valves welded onto a pipe section according to customer specifications. Flaring is thus avoided and only a girth weld is required.

MAINTENANCE

The rubber membrane should be replaced every two months. PTFE membranes should be replaced every 12 months. In the event of intensive sterilisation and cleaning it may be necessary to replace it more frequently. For valve heads with Micro Port, approx. 5-10 samples may be drawn off per membrane at 5-2 bar(g) respectively. The rubber plug must be replaced at least once every six months. In each individual case a standard operating procedure including maintenance intervals should be endorsed based on experience. For disassembly of valve body and valve head, see instructions.

Spare parts list

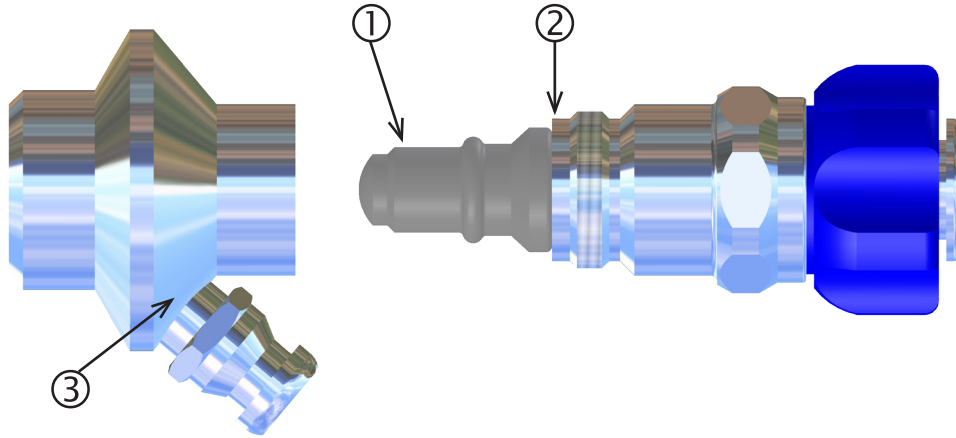

Pos. Item

- 1. Membrane Silicone (grey)
Membrane EPDM (black)
Membrane PTFE (White)
- 2. Steel bushing
- 3. O-ring

Disassembly and assembly of valve body and head

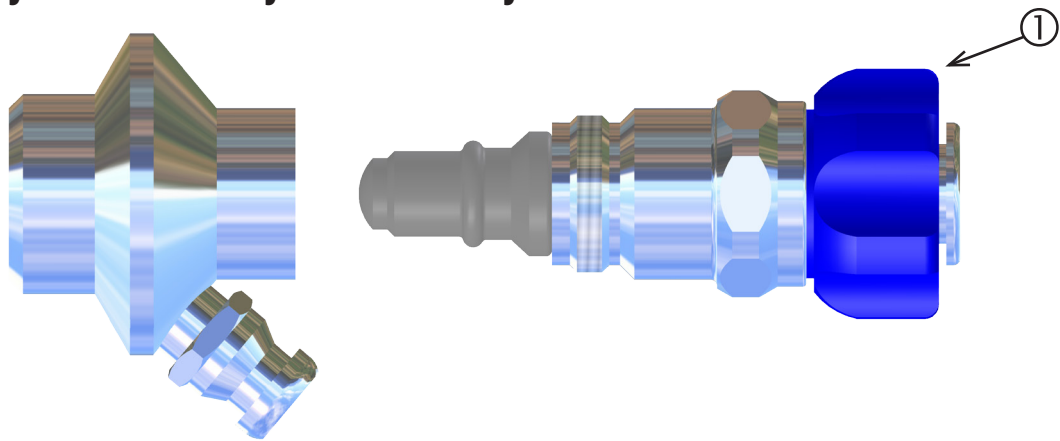

ORDER OF OPERATION:

Remember! When replacing the membrane, set the valve head in the open position before it is screwed loose and pulled out of the valve body. Omitting to do so may result in twisting and cutting of the membrane.

- 1. Set the valve head at the open position by turning pos. 1 counter clockwise.
- 2. Remove the valve head by turning it clockwise until loose and then pulling the valve head off.
- 3. Refit the valve head (in the open position) once the necessary parts have been replaced.

SILICONE MEMBRANE - ITEM NO. 600051

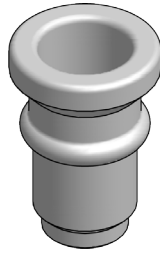

TECHNICAL SPECIFICATION

- | | |
|--|--------------------|
| • Type: | Silicone |
| • Colour: | Grey |
| • Resistance to chemicals acids/bases) | Suitable |
| • Food safe | Yes (FDA*) |
| • Temp. range | 1-130°C / 34-266°F |
| • Steam pressure max. | 2 bar/29 psi |
| • Process pressure | 1-6 bar/14-87 psi |

Keofitt recommends to change the silicone membrane 4-6 times a year or as needed. The recommendation is based on 1-5 samples a day, but should reflect individual tear and wear from individual cleaning and sterilisation procedures.

*FDA approved compound according to Code of Federal Regulations Title 21 - § 177.1550

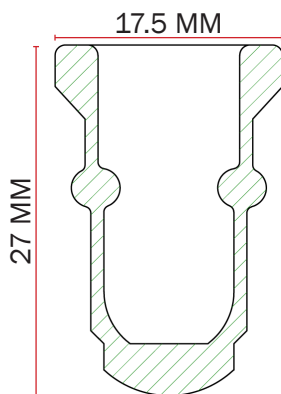

EPDM MEMBRANE - ITEM NO. 600052

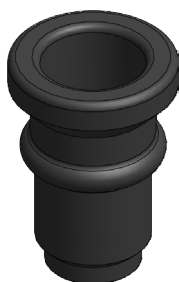

TECHNICAL SPECIFICATION

- | | |
|--|-----------------------|
| • Type: | EPDM |
| • Colour: | Black |
| • Resistance to chemicals acids/bases) | Very good |
| • Food safe | Yes (FDA*) |
| • Temp. range | 1-130 °C / 34-266 ° F |
| • Steam pressure max. | 2 bar/29 psi |
| • Process pressure | 1-6 bar/14-87 psi |

Keofitt recommends to change the EPDM membrane 4-6 times a year or as needed. The recommendation is based on 1-5 samples a day, but should reflect individual tear and wear from individual cleaning and sterilisation procedures.

*FDA approved compound according to Code of Federal Regulations Title 21 - § 177.1550

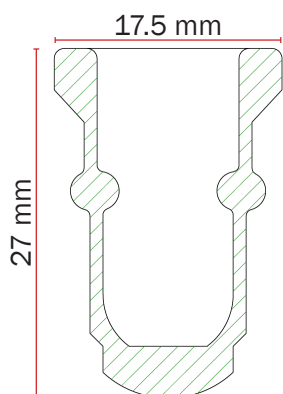

PTFE MEMBRANE - ITEM NO. 850055

TECHNICAL SPECIFICATION

- | | |
|--|--------------------|
| • Type: | PTFE |
| • Colour: | White |
| • Resistance to chemicals acids/bases) | Excellent** |
| • Food safe | Yes (FDA*) |
| • Temp. range | 1-150°C / 34-302°F |
| • Steam pressure max. | 2 bar/29 psi |
| • Process pressure | 1-6 bar/14-87 psi |

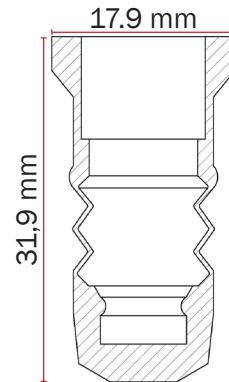
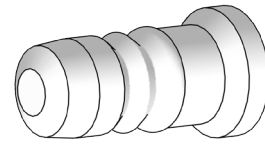

Keofitt recommends to change the PTFE membrane once a year or as needed. The recommendation is based on 1-5 samples a day, but should reflect individual tear and wear from individual cleaning and sterilisation procedures.

*FDA approved compound according to Code of Federal Regulations Title 21 - § 177.1550

** Is not attacked by common chemicals, with the exception of strongly oxidising acids.

INSTRUCTIONS ON REPLACING PTFE MEMBRANE

1. Open valve.
2. Remove the valve head from the valve body.
3. Push the membrane upwards until the tool for membrane fits under it.
4. Insert tool for membrane, between the membrane and the bushing.
5. Close valve head.
6. Now the membrane is loosened from the valve head and can be replaced.

To attach new membrane to valve head.

7. Set the valve head to closed position.
8. Place the new membrane on valve head.
9. Mount the membrane bushing with the new Teflon membrane by pressing the membrane with your hand until it clicks.
10. Set the valve head in open position.
11. Insert the valve head into the valve body.
12. Close valve head.



IMPORTANT

- Once the membrane has been removed from the valve head the click system in the membrane might be damaged. Therefore the membrane might be unsafe for further use and it is recommended not to use the membrane again.
- Do not use hammer or other tool that might scratch the surface of the membrane.



Tool for membrane item no. 600255

Keofitt reserves the right to change technical data without notice!
For complete set of updated data sheets and manuals for Keofitt products please refer to our web page www.keofitt.dk

